

# Heat Staking: Inserting Metal into Plastic

By Dr. Girish Dahake, Ambrell Senior Vice President of Worldwide Applications

## Introduction

One of the most common uses for induction heating is the heat staking of threaded metal inserts into plastic. Most thermo-plastics are too soft to sufficiently hold a thread, so brass or steel threaded inserts are added. Post-molded installation is more cost-effective than molding in place and induction is a proven way to pre-heat the inserts prior to installation.

For heat staking, the insert is preheated with induction and then pressed into a hole in the plastic part. This is accomplished by positioning the induction coil over the hole and then holding the insert in the coil

for a short period of time. When the correct temperature is achieved, the insert is pressed into the plastic. A narrow zone of plastic then melts and flows into the knurls of the insert. The plastic re-solidifies, resulting in a complete assembly with much better mechanical properties than inserts implanted with other techniques.

The insert material is usually brass or steel; each has advantages and disadvantages. Brass is non-magnetic and will not corrode as easily as steel. However, brass is a softer material and will anneal at temperatures as low as 450°F, whereas steel starts to anneal at 1200°F.

Some glass-filled plastics require inserts to be heated to 700°F for correct installation, so the brass inserts must be heated and inserted quickly to prevent thread annealing. Brass has low electrical resistivity and therefore requires more power to heat with induction than steel.

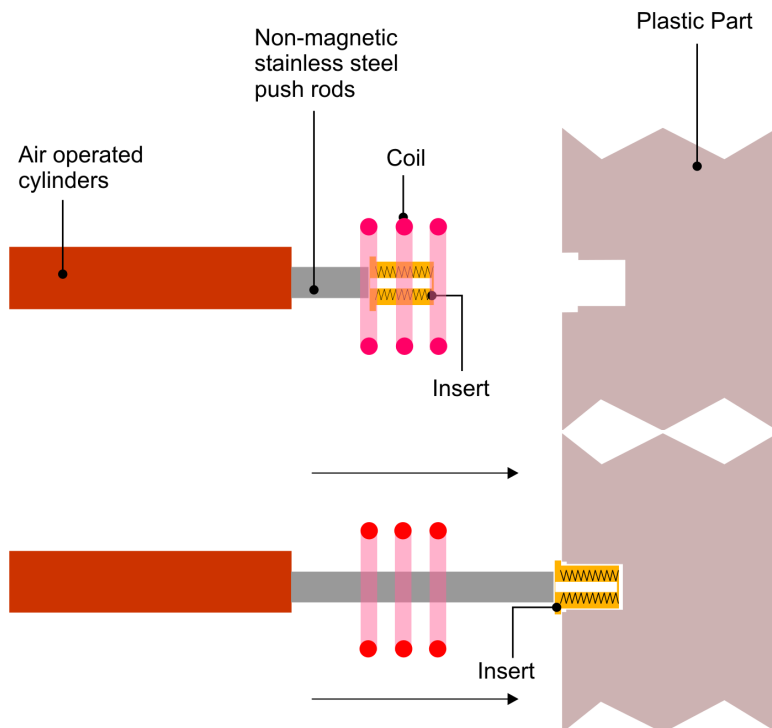

Introduction .....	1
Basics of Metal-to-Plastic Bonding.....	4
Simultaneous Heat Staking of Three Steel Inserts .....	7
Inserting Metal Parts Accurately .....	8
Staking Steel Inserts into a Chair Frame .....	8
Attaching Plastic Handles to Steel Flatware.....	9
Staking Plastic Bearings on Steel Shafts .....	10
Bonding Electrical Connector Components .....	10
Inserting Plastic Handles into Metal Control Arms.....	10
Heat Staking Large Brass Inserts .....	11
About Ambrell.....	12

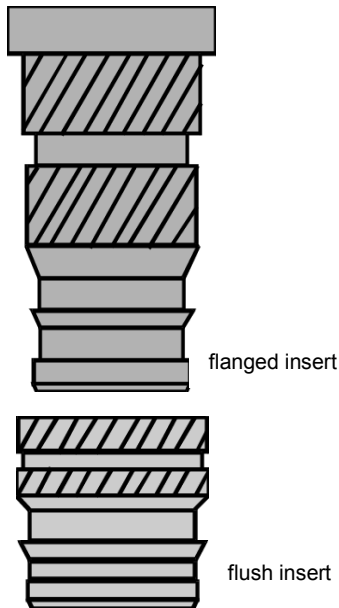

Fig. 2: Different insert types

A steel insert can be heated more quickly because steel has high resistivity and is harder than brass, and there is no concern about annealing at the insertion temperature of most plastics. However, consistent coating or plated finishing of steel inserts, particularly in the threads, can be difficult to achieve because steel inserts are typically magnetic and oxidize more quickly than brass. The selection of the insert material is dependent on the specific application requirements, but brass is often the material of choice due to the coating and plating issues.

There are also other factors to consider: the insert must have the proper knurl and fin design to achieve the desired rotational torque and tensile strength. Most inserts designed for molded-in, expansion, ultrasonic or self-threading insertion can be used with the induction heating process. However, due to the inductively heated insert's ability to easily reflow plastic, the knurls and fin on the insert can be made deeper for greater holding strength. The material and mass of the insert, together with the available heating time, will determine the power required to reach the desired temperature.

The installation temperature of the insert is important. Each insert must be heated to the same temperature in the same time to achieve a consistent process.

The critical parameters for a consistent induction insertion process are:

- power-on cycle in the induction power supply
- heat-on time
- tuning frequency
- power ramp-up and ramp-down
- positioning of the insert in the coil
- insertion pressure
- thermoplastic material

Thermoplastics will flow at elevated temperatures and the solidified polymer can be reheated to reflow around the insert. Thermosetting polymers, once the shape has been cast, will no longer melt or flow on reheating. Table 1 shows some typical temperatures, time and power required for different materials, as established in the Ambrell Applications Lab.

The diameter of the insert hole must be the correct size to allow the plastic to flow around the insert. If the hole is too small, extra plastic will be displaced. This displaced plastic is commonly called 'flash.' Excessive heat and pressure may also cause flash. If the hole is too large, not enough plastic will flow into the fins and knurls to achieve the desired holding strength.

With proper fixturing, tight center-to-center tolerances of the inserts can be maintained. Although molded plastic parts sometimes do not have tight tolerance, post-molded installation with induction heating and accurate insert location tooling will put the insert in the same location each time, even if the holes in the plastic vary in size.

Qty.	Material	Insert Size; Ø,lg (in)	Temp (°F)	Time (sec)	Power (kW)	Model (kW)
1	brass	.33, .50, .17 wall	400	1	.3	1
1	brass	.33, .50, .10 wall	400	.8	.3	1
1	brass	.25, .63	400	2.5	1.2	3
4	steel	.63, .50, .12 wall	500	12	.6	1
2	brass	.25, .50, .12 wall	350	2	.8	1
1	brass	.56, 1.25	700	6	.8	1
1	steel	.75, .05	250	2	.7	1

Table 1: Typical heating times, temperatures and power required for different materials

There are several methods used for inserting with induction heat. An x - y positioning table (see Figure 3) can be used in conjunction with a single position coil when multiple inserts need to be installed in a single molded part. The position of the coil is held constant and the x - y table moves each insert location under or above the coil. This technique provides for a flexible manufacturing tool that can be changed by software programming rather than hardware tooling changes.

As shown in Figure 4, a second option for a single position coil is the use of a robotic arm. The plastic part is held in fixed location while the coil and indexing mechanism can be moved to each insert location. Encapsulated heat stations are available from Ambrell for this purpose. Small encapsulated heat stations can be supplied

with 1, 3, 5 and 7.5 kW power supplies with mounting brackets to align with robotic insertion tooling. Location of the coil relative to the heat station is custom-designed for each application.

A multiple-position coil makes it possible to install more than one insert at a time into a single plastic part. Three- and four-position coils have been used for this application. For this setup, the coil is normally in a fixed position and the plastic part is moved into the coil. The inserts for each location are heated simultaneously and then pressed into the plastic.

For all tooling arrangements with induction heat, the manner in which the insert is held is more important than with other insertion methods. Using metallic tools to hold the insert in the coil will impede the

performance of the induction power supply. Any tooling in direct contact with the inserts should be nonmagnetic and have the smallest mass possible. Non-magnetic stainless steel is often used for the rod which locates and inserts the part.

The insert threads should not be used for holding, as this can damage the threads during insertion. Three jaw chucks or a combination of a locating rod and vacuum can be used for holding the insert. With each method, a taper or some other centering mechanism should be incorporated into the design. Gravity is often used to position the inserts onto the insert tooling, and the inserts are normally pushed upward or horizontally into the plastic.

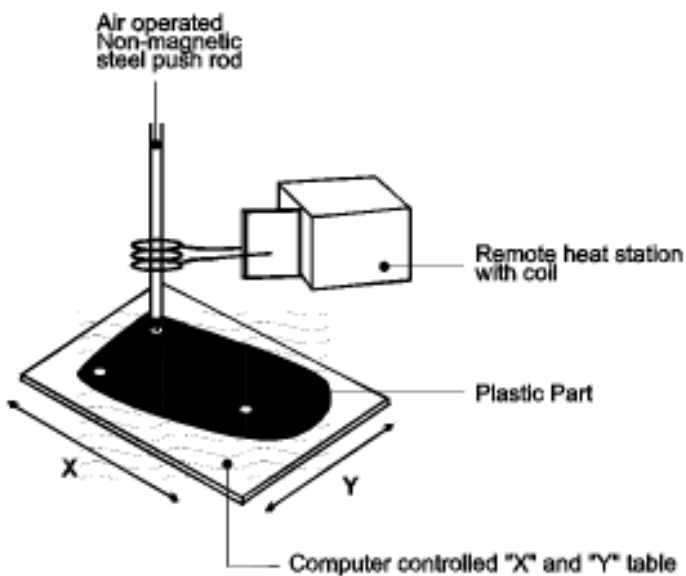

**Figure 3:** Stationary inserter, variable "X" and "Y" table

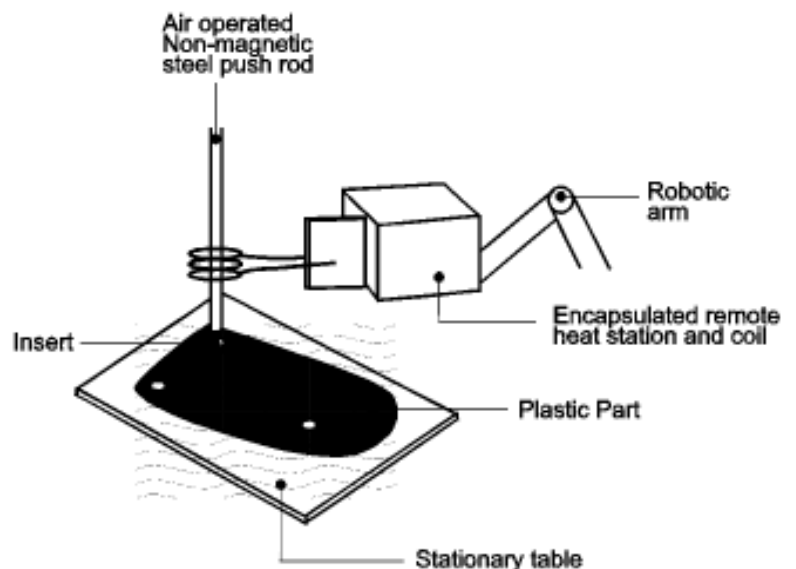

**Figure 4:** Stationary table, variable position inserter

## Basics of Metal-to-Plastic Bonding

Since steel, brass and aluminum are the materials of choice for metal inserts for plastic bonding, let us look at the relative merits of each material and see how each characteristic affects the ability of the material to be heated and inserted into the plastic part. Material resistivity, permeability, specific heat and thermal conductivity are the four primary properties to consider when heating a metal insert with induction. Each of these materials can be heated by induction, but the individual material properties will dictate the characteristics of the induction process. Table 2 shows the characteristics of 3/8" OD inserts made from steel, brass and aluminum when heated with the same magnetic field produced by a coil with the same current passing through it and the same number of turns. The steel insert absorbs more power from the magnetic field so it is heated faster than the aluminum and brass inserts. The induction process produces heat in the insert by creating an electrical current that flows around the part. This induced current flows through the resistivity of the material causing

heat to be generated within the insert. The current flows towards the outside surface of the part with most (80%) of it flowing in an area known as the skin depth. The skin depth is dependent on the resistivity and permeability properties of the material. Table 2 shows the steel insert with a skin depth of 0.0025", compared to the brass of .008", showing that the heat induced in the steel part is produced in an area 2.5 thousandths of an inch in from the surface, while the brass is 8 thousandths of an inch. This has several effects on the induction process. With a steel insert, the heat is produced closer to the edge, so care must be taken not to melt the outer surface during fast heating cycles. The heating time must be long enough to allow sufficient energy to be transferred to the insert to allow for proper bonding when inserted into the plastic. The .008" skin depth of the brass insert produces the heat more into the part but dictates that small diameter inserts must be heated with higher frequencies to maintain heating efficiency. For optimum efficiency, the diameter of the insert must be greater than 4x the skin depth. The skin depth is given by the fundamental equation:

$$d = 3160 \sqrt{\frac{\rho}{\mu f}}$$

where:

d the skin depth in inches  
 ρ the resistivity in mΩ-inches  
 μ the permeability of the metal  
 f the operating frequency (Hz).

This formula dictates that in order to achieve efficient heating for small inserts, the operating frequency of the induction equipment must be above 50 kHz. When taking into account the overall size of the insert, the available insert length for an effective coil and the resulting small number of turns and low coil inductance, operating frequencies in the 300 to 450 kHz are required for efficient coil/part energy transfer.

The amount of energy required to heat the insert depends on the mass of the insert and on the specific heat of the material described by the following equation:

$$Q = \frac{m C_p \Delta T}{57}$$

where:

Q = quantity of heat (kW)  
 C<sub>p</sub> = specific heat (BTU/lb °F)  
 ΔT = rise in temperature (°F)  
 m = mass (lbs./minute)

	Aluminum	Brass	Steel	units
Resistivity	1.11	2.76	29.0	μΩ•inch
Skin depth	0.005	0.008	0.0025	in
Specific heat	0.214	0.092	0.118	Cal/gm•°C
Thermal conductivity	211	395	52	
Temperature	350	350	350	°F
Time-to-heat	3.2	3.0	1.1	sec
Power absorbed/insert	350	484	560	W

Table 2: 3/8" OD inserts in same magnetic field in a coil with same number of turns and same current.

The power required by the insert is indirectly related to the time taken to heat it. If the heating time is increased from one second to three seconds, the amount of power required would decrease to 205 Watts. Although the power required to heat the brass and aluminum inserts is less than steel, the power absorbed from the magnetic field as shown in Table 2 is far less than the steel insert. So the steel parts heat much more efficiently than the brass or aluminum and require much less power from the power supply.

This means that, with the properly designed induction coil, a 1 kW induction power supply can be used to heat one aluminum insert, two brass inserts or three steel inserts at a time.

Having looked at the material properties affecting the heating cycle, let us now look at the material characteristics which affect the insertion process. Specific heat and thermal conductivity are the primary properties to consider. Since the induction process produces heat towards the outside of the metal part, the heating pattern should be considered relative to the process time.

At the end of the heating cycle the surface of the insert is at a relatively higher

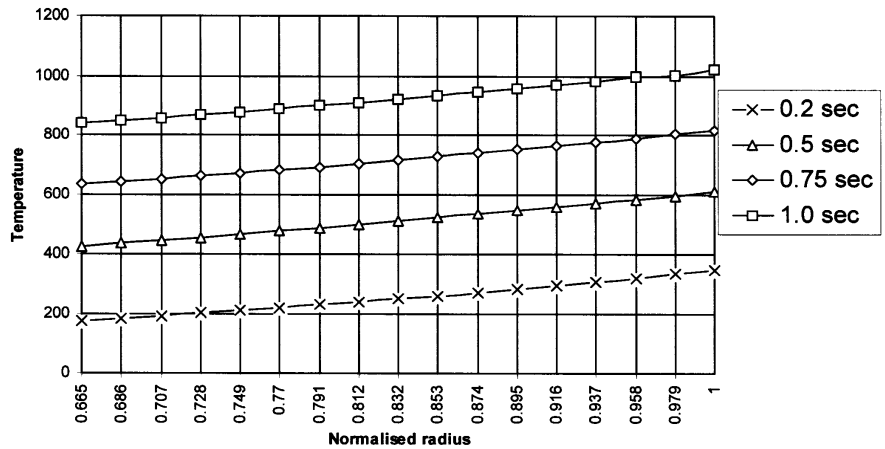

**Figure 5:** Temperature through the cross section of the steel insert, 3/8" O.D. A specially designed 4-turn double wound helical coil is used on the 1 kW power supply for the heating.

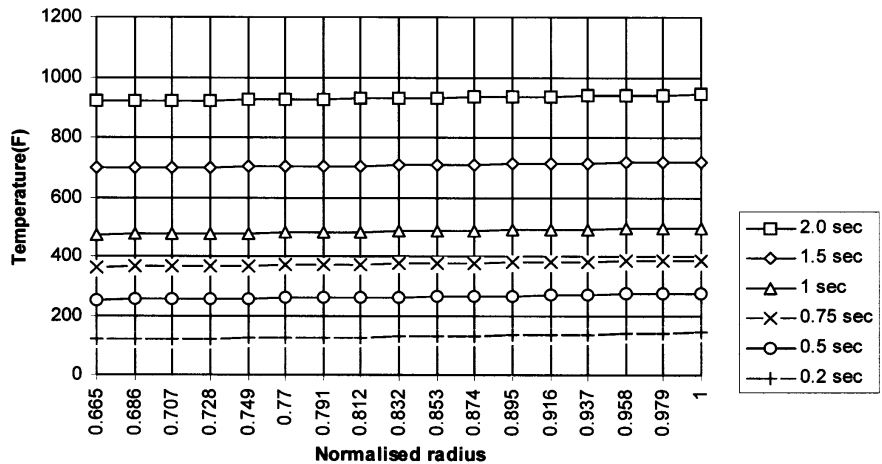

**Figure 6:** Temperature through the cross section of the brass insert, 3/8" O.D. A specially designed 4-turn double wound helical coil is used on the 1 kW power supply for heating.

temperature than the inside. However, due to the thermal conductivity of these materials, the insert quickly reaches a uniform temperature throughout. When the 3/8" O.D. of a brass insert is heated to 3500°F in one second, it will only take 60 milliseconds for the center

thread surface to reach temperature equilibrium. The steel insert will take 25 milliseconds. A short heat cycle and dwell time prior to insertion will minimize the possibility of thread annealing.

**Table 3:** The amount of power required to heat 3/8 inch diameter inserts to 350°F in one second.

	Aluminum	Brass	Steel	units
Mass	0.0058	0.0184	0.0165	lbs
Specific heat	0.214	0.092	0.118	
Temperature rise	300	300	300	°F
Power required	390	535	615	W



After the heating cycle, during the insert location and before the actual insertion, the insert loses heat by radiation and convection. Heat is also lost to the fixture holding the insert. As shown in Figure 7, the drop in surface temperature is almost exponential. It is therefore important that the insert is pushed into the plastic as soon as possible after the end of the heating cycle. A brass insert

is pushed into the plastic. The temperature of the insert drops much more rapidly after insertion because it loses heat in melting the plastic and by conduction into the plastic. A comparable curve for steel is shown in Figure 8. Steel inserts can be heated very quickly; due to the poor thermal conductivity of steel and the surface temperature of steel will be at a much higher temperature than the center of

The heat content of the metal insert just before it is pushed in the polymer should be sufficient to melt the polymer to a plastic state and have a good flow around the insert. The interference between the insert and the guiding bore in the polymer determines the amount of polymer to be displaced. It is usually not enough just to heat the insert to the melting point of the plastic.

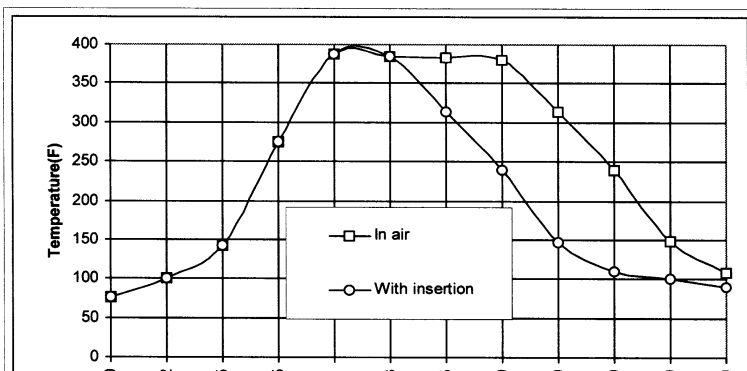

**Figure 7:** Temperature of a 3/8" brass insert in air and when inserted in plastic. The insert is heated for 1.0 seconds and should be inserted within 5 seconds to obtain good capture of the plastic around the insert.

must be inserted within five seconds of the end of the heating cycle; otherwise the insert will have lost sufficient

the insert. As seen in Figure 8, at the end of the heating cycle the temperature of the surface of the insert drops rapidly as the

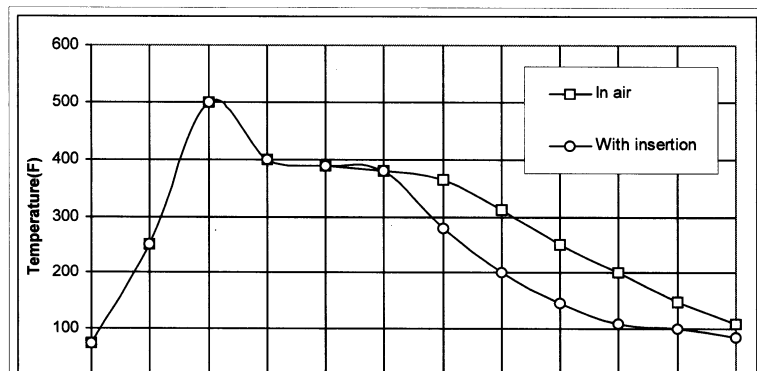

**Figure 8:** Temperature of a 3/8" steel insert in air and when inserted in plastic. The insert is heated for only 0.4 seconds and then inserted within 3 seconds to obtain good capture of plastic around the insert.

heat to melt and flow the plastic.

Figure 7 also shows the surface temperature of the insert when it

heat travels through to the center of the insert until the whole insert reaches the equilibrium temperature (400°F).

The insert has to be sufficiently heated so that the heat content stored in the insert is enough to raise the temperature of the polymer at the interface to the melting temperature, and also have enough heat to overcome the latent heat of fusion of the polymer. The latent heat of a substance is the amount of heat required at the melting temperature to change the phase from solid to liquid. This depends on the particular plastic used. A brass insert at 350°F could not be inserted into a plastic which melts at about 200–250°F. The insert must be heated to a temperature of about 400°F to get a good insertion. The insert must be heated to a temperature higher than the melting temperature of the plastic to get a good flow of plastic around it. Yet, the insert must not be too hot; or the plastic will burn or boil creating excessive flashing.

Once the insert has been pushed in the polymer, a temperature gradient arises in the polymer; the temperature is hottest at the insert/polymer interface and drops exponentially away from it. The locating fixture should be held

stationary after insertion for the polymer to re-solidify around the insert. For the 3/8" brass insert, a hold time of 0.5 seconds is

also be used. With a 1 kW power supply, only one aluminum insert can be heated, where two of brass and three of steel can be

with good capture of plastic around the metal insert.

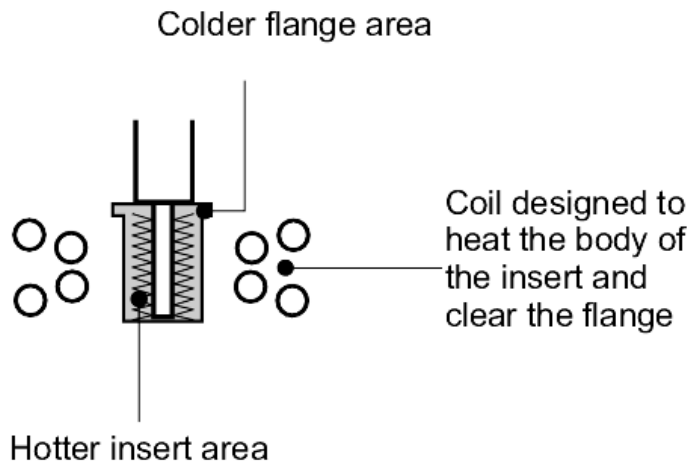

**Figure 9:** Typical coil design and positioning for heat staking

usually sufficient to allow the plastic enough time to re-solidify to maintain the tolerance required by the insert. The hold time depends on a number of factors: the insert material, the insert temperature at the time of insertion, the amount of polymer displaced and the temperature characteristics of the polymer. The melting point and viscosity of the polymer will determine the required temperature for satisfactory insertion.

The process of staking the metal insert into the plastic depends upon the material characteristics of both the insert and the plastic. During the heating process, a proper coil design (see Figure 9) is required to transfer power efficiently and quickly to the insert. Although steel is easiest to heat, brass or aluminum can

be heated in the same time using properly designed coils. Cycle times can therefore be reduced by using steel or brass inserts. The insert must be heated to a temperature higher than the melting temperature of the plastic, and the insert must be pushed into the plastic within two to five seconds depending on the size of the insert. Heat lost by radiation and convection, as well as the heat lost by conduction to the inserting fixture, must be accounted for in the design of the process. A good capture of plastic is vital for good pull strength and resistance to torque. Thus, the optimum insertion process depends on a properly designed coil, metal insert and the guiding hole. The insert must also be heated to the right temperature to have a good strong product

## Simultaneous Heat Staking of Three Steel Inserts

There are many plastic molding applications that require an assembly with two or three inserts. By simultaneously heating the inserts with induction in a multi-position coil, the inserts can be pushed into the part at the same time, optimizing throughput and yield. An automotive door handle required three steel inserts to be placed in three separate locations on the handle. All three locations were on different plains, but were inserted from the same side. The steel inserts are relatively easy to heat with induction energy, so a multi-position coil designed for the same hole positions as the inserts on the handle will heat the three steel parts to 375°F in 2 seconds. The coil is in a single plane and the insert push rods are designed to correctly place each insert into the door handle on a five-second cycle time. These steel inserts have a 0.5" diameter flange which has to seat on the door handle, but not melt into the surface. By designing the coil correctly and properly positioning the part in the coil, the body of the insert can be heated to a higher temperature than the flange.

## Inserting Metal Parts Accurately

It is often necessary to locate the metal inserts in the molded plastic part with greater accuracy than is achievable with ultrasonic insertion techniques. Errors in the precise location of the holes in some plastic moldings cause parts inserted ultrasonically to “wander” from the required location. By using induction heating to heat the insert, and with accurate insert location,

inserts can be positioned to correct the location errors in the holes in the molded part. As the heated insert causes the plastic to melt and flow, 0.03 to 0.10 inch correction in the location of the insert is achievable. In the application illustrated in Figure 11, an air nozzle required two inserts to be accurately positioned relative to one face independent of the molded hole spacing. By accurately locating the insert push rods relative to the part, the inserts could be precisely inserted into the

molding with a loosely coupled two-position coil. A 1 kW Ambrell solid state power supply was used for this application. Heating the two inserts produced a total cycle time of one part in every five seconds, with the insertion and cure time taking an additional three seconds. The inserts were heated to 350°F and the system operated at a frequency of 207 kHz with 275 Watts loaded into both inserts.

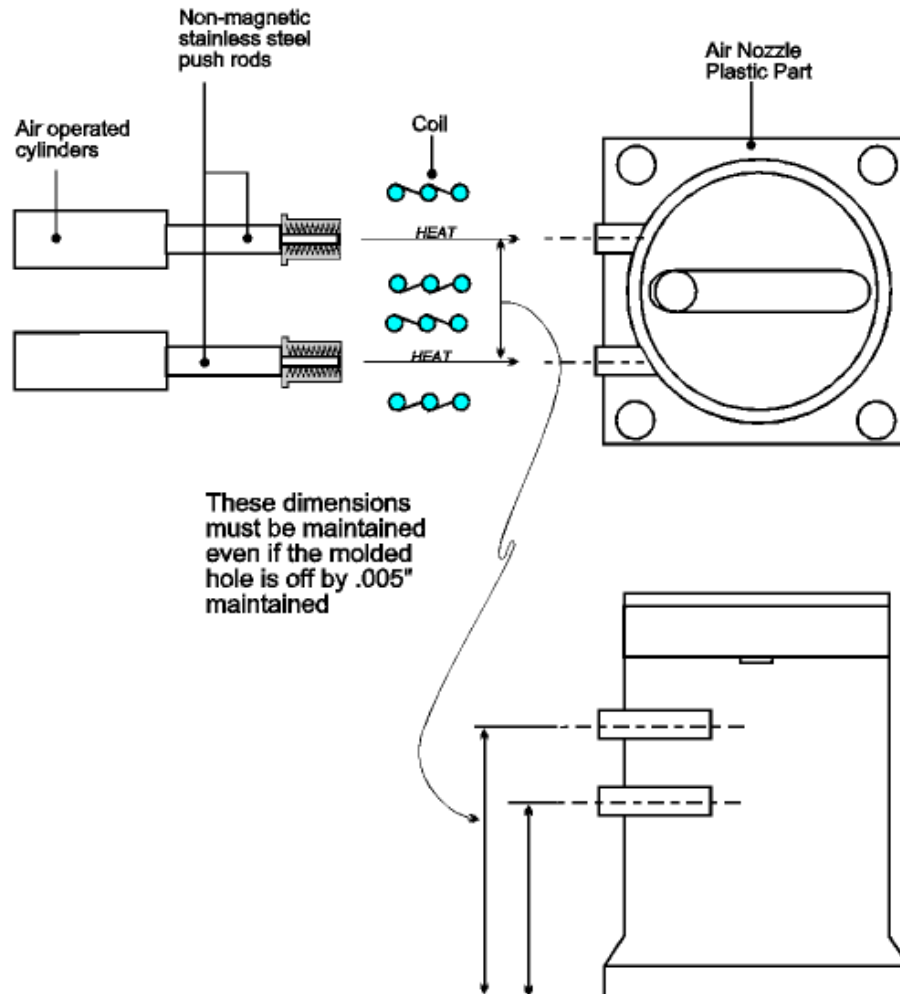

Figure 11: Accurate insertion metal parts with precision induction heating



## Staking Steel Inserts into a Chair Frame

Standard office chairs often have a metal leg assembly with a molded plastic body attached with steel fasteners. Metal inserts are screwed into the plastic chair body, with the leg assembly bolting to it.

Unfortunately, the retention and torque strength of the threaded metal inserts is not very reliable, and the assemblies tend to loosen over time.

When induction is used to heat the insert, the insert becomes an integral part of the plastic chair body. The steel insert is heated to a temperature high enough to melt the plastic upon insertion.

The plastic re-flows around the knurls, cures, and forms a lasting bond. Once it has cured, the retention and torque strength is extremely high, and the process can be duplicated quickly and consistently.

In the application illustrated below, four steel inserts are heated simultaneously with a multi-turn, multi-position coil. The inserts are positioned in the coil using nonmagnetic stainless steel push rods; and are heated to 600°F in approximately thirteen seconds, before insertion into the 30% glass-filled plastic chair body at 490°F. The induction heating insert process has a much higher retention strength and positional accuracy than can be achieved with the threading process.

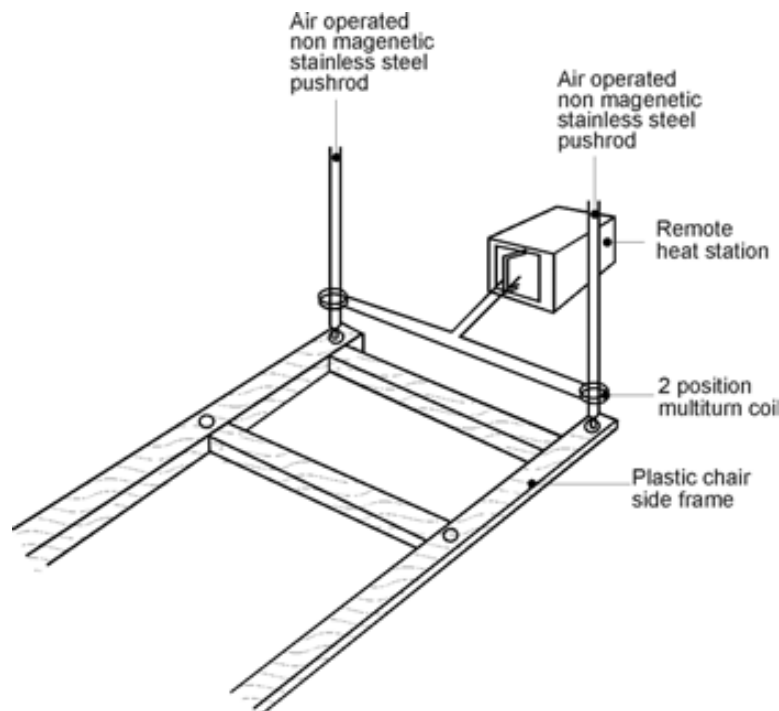

Figure 12: Setup for heat staking steel inserts into a plastic office chair frame.

## Attaching Plastic Handles to Steel Flatware

The cutlery industry has many requirements for attaching plastic handles on steel flatware. Many types of pocket knives, dinner knives, forks and spoons incorporate plastic handles. Induction heat is used to heat the tang of the flatware either before or after attaching the plastic handle. In one application, a plastic handle was positioned on a pancake coil and the flatware tang aligned at the end of the handle (opposite end of the coil). Power was applied to the coil and the tang/ handle assembly was moved into the coil center position. The tang was pushed into the handle as the ABS melted, and the entire assembly was removed from the coil as the tang fully seated. The time to complete the operation was four seconds. This application required a frequency of 270 kHz and 200 watts of power to raise the tang temperature to approximately 350°F. This allowed the plastic to form correctly around the tang, but was not so much heat that the handle lost its molded shape. The pancake coil design was used so the staking process could be directly incorporated into the assembly line.

## Staking Plastic Bearings on Steel Shafts

With the advances in polymer applications for bearing surfaces, there are many applications which involve the attachment of a bearing assembly to a steel shaft. In the automotive industry, plastic bearing assemblies are often used on the end of air spring

simultaneously heated in a multi-position coil with a 3 kW power supply and an encapsulated remote heat station. The heat station and coil assembly moved over the two steel shafts and heated the ends of the shafts to 1300°F in less than two seconds before moving back from the shafts. The plastic bearing assemblies were placed on the ends of the shafts, 880 Watts of power was delivered to each end, and the total cycle time was

and moving the coil and encapsulated heat station for the heat cycle, a more reliable automated process was achieved.

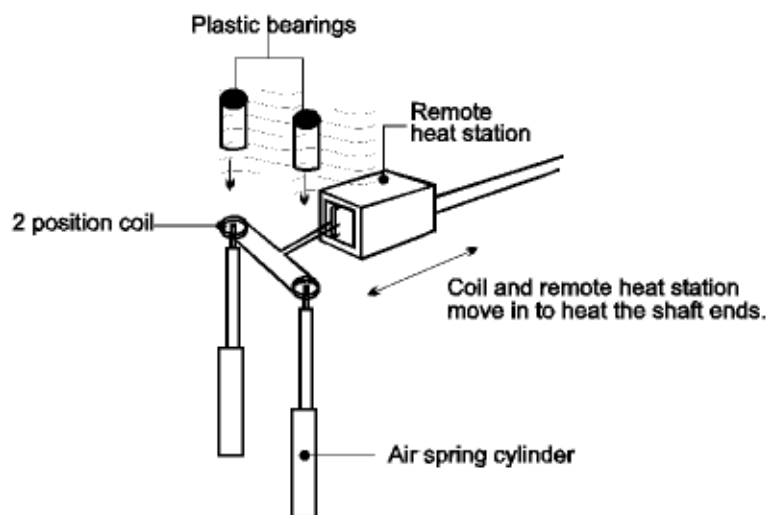

cylinders to aid the opening of hoods and trunks. In the application illustrated below, the ends of two steel shafts were

approximately 15 seconds. The high temperature of the ends to allow for cooling after the shafts have been removed from the

## Bonding Electrical Connector Components

Many two-part electrical connectors are held together using a mechanical threaded screw.

0.25 inch OD brass inserts are often used to provide the robust thread in the plastic connector body. Induction heating can be used to heat these with precision and consistency

Figure 15 illustrates how a 0.25" OD 0.625" long brass insert is heated to 600°F in two seconds prior to insertion in the glass-filled plastic connector housing. 1225 Watts is delivered to the part from a 3 kW induction power supply.

Since the hole in the connector is a through hole rather than the usual blind hole, a guide rod can pass through the plastic housing

*Figure 14: Setup for staking plastic bearings on steel shafts.*

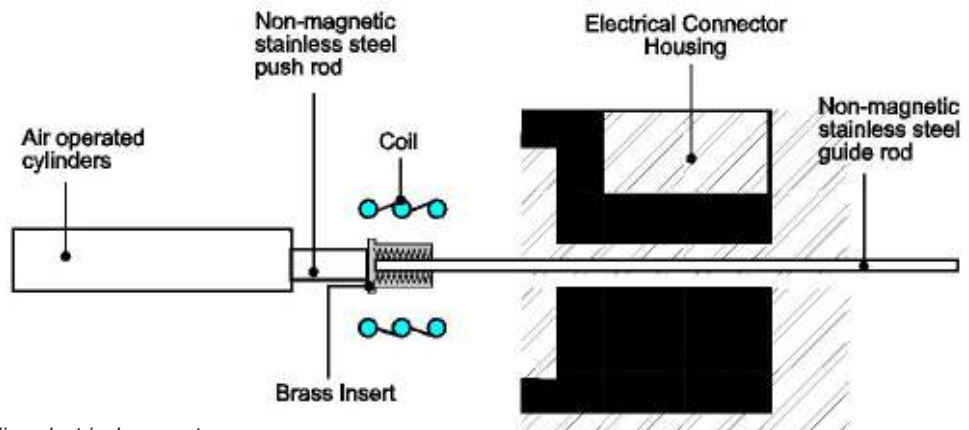

*Figure 15: Setup for bonding electrical connector housing components*

## Inserting Plastic Handles into Metal Control Arms

Agriculture and yard care equipment often have metal control arms with plastic handles. The plastic handles are threaded onto the metal control arms which can eventually loosen, and could become a safety concern if the handle were missing or broken due to continuous adjustment. With induction heating, the molded handle and metal assembly can be permanently fused together with a better torque strength than can be achieved with the simple threading technique.

During manufacture each control arm/handle assembly is processed with the same coil and power supply, using different heating times as necessary. A control arm is inserted into its corresponding

handle and the assembly placed over the coil. Power is applied and the handle pressed onto the control arm as heating occurs. In one lab application, the steel control arm reached a temperature of approximately 400°F and heating times varied from two to six seconds depending on the assembly.

## Heat Staking Large Brass Inserts

Automobile inlet manifolds are molded from glass-filled nylon and bolted to the engine using 9/16 inch diameter brass inserts. Eight to ten of these large inserts are usually positioned on one plane with a number of smaller inserts in another plane to mount the EGR components and air duct or filter assemblies.

The 9/16 inch diameter brass inserts require 475 Watts of

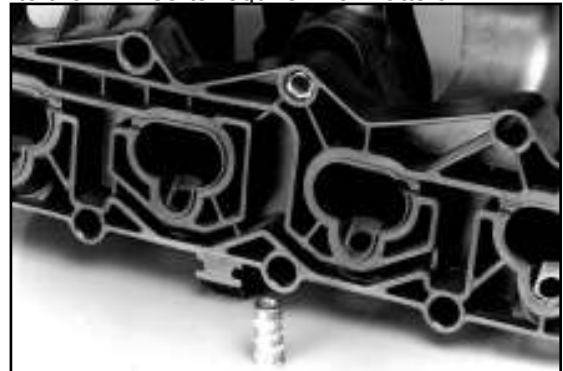

delivered power to reach the required insert temperature of 700°F within four seconds. Each insert is placed on a non-magnetic stainless steel push rod which is activated by an air cylinder. The insert is placed in the coil and heated for four seconds before being inserted into the manifold. The stainless steel push rod positions the insert in the manifold and passes through the coil. Heat is applied only while the insert is in the coil; the power is switched off during the rest of the cycle so as not to heat the stainless push rod.

Multiple coils are required to heat the 10 inserts simultaneously, and these are located in a "heating plate" that the inserts pass through. The coils can be part of a two- or multiple-position coil, or be individually driven by 1kW power supplies. The smaller inserts can also be inserted at the same time with a separate coil and inserter push rod system. Typical cycle time is 10 to 15 seconds per manifold.

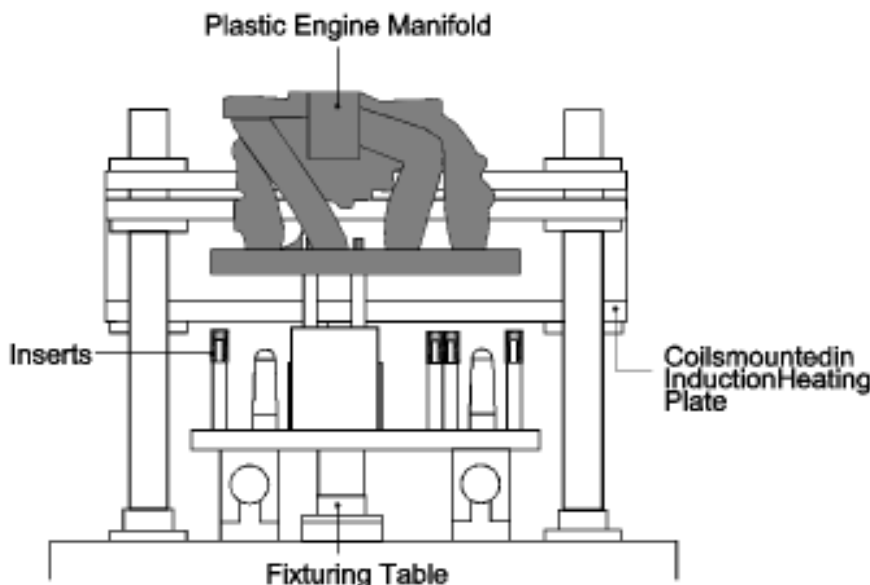

**Figure 16:** Fixturing table for inserting large brass inserts into engine manifold

## Ambrell Power Supplies

Ambrell manufactures a wide range of power supplies, both low and high power for an array of applications. For heat staking, the EASYHEAT (1-10 kW) and the low power end of the EKOHEAT (10-15 kW) product lines are most popular.

Ambrell power supplies have movable workheads so the coil can be placed a distance from the power supply, a high power factor to ensure efficient heating, significant versatility with multiple capacitor and tap configurations, and repeatable, reliable heating with agile frequency tuning. Additionally, systems are compact and easy-to-integrate into manufacturing processes.

Systems are manufactured at Ambrell's ISO 9001:2008 certified facility at its headquarters in Scottsville, NY USA.



## Complimentary Applications Testing

You can send parts to Ambrell's Applications Laboratory for a free half-day of testing. Testing is recorded and parts are sent back to you for inspection. Additionally, you are welcome to visit during testing to see induction heat staking live.

After testing, you will receive a tailored system recommendation. The recommendation will be based on your process requirements, including process time, cycle time and temperature.

Heat staking is a common application at Ambrell. So take advantage of that expertise and send in your parts for risk-free applications testing today.

## About Ambrell

As a pioneer in solid-state induction heating technology, with over 25-years of innovation, Ambrell provides industry-leading heating solutions. We pride ourselves in making it easy for you to implement an efficient, safe, rapid induction heating process by applying our knowledge of the science and art of induction

to your heating application. Ambrell is headquartered in the United States with worldwide operations including Ambrell Ltd. in the United Kingdom, Ambrell SARL in France and Ambrell B.V. in the Netherlands.



**Ambrell Corporate**  
39 Main Street  
Scottsville, NY 14546  
tel: +1 585 889 9000  
fax: +1 585 889 4030  
sales@ambrell.com

**Ambrell, Ltd.**  
Phoenix Works, Saxon Way  
Battledown Industrial Estate  
Cheltenham, Gloucestershire  
GL52 6RU  
tel: +44 (0)1242 514042  
fax: +44 (0)1242 224146  
salesuk@ambrell.com

**Ambrell B. V.**  
Holtersweg 1  
7556 BS Hengelo  
The Netherlands  
Tel: +31 (0)880 150 100  
Fax: +31 (0)548 659 010  
saleseu@ambrell.com

**Ambrell SARL**  
Tour Sébastopol  
3 quai Kléber  
67000 Strasbourg  
France  
Tel: +33 970 440 335  
Fax: +33 38 9748533  
saleseu@ambrell.com